

Planning Guidelines for Plant Monitoring

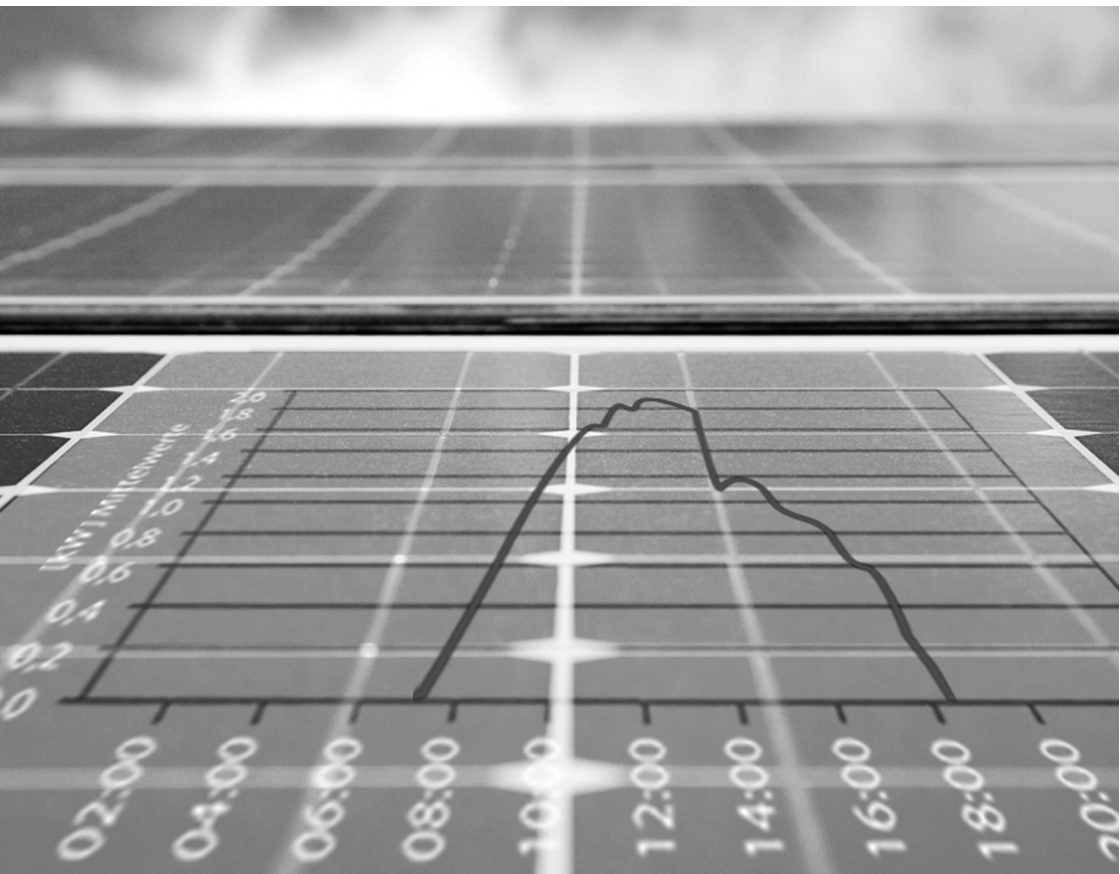

Table of Contents

1	Introduction	5
2	List of the Product-Specific Abbreviations	5
3	Monitoring Options for Sunny Boy, Sunny Mini Central and Sunny Tripower	6
3.1	Sunny Beam System with <i>Bluetooth</i> ® Wireless Technology.	6
3.2	Inverter – Computer Direct Connection	7
3.3	Inverter – Sunny WebBox Connection	9
3.4	Inverter – Sunny WebBox <i>Bluetooth</i> Connection	10
3.5	Inverter – Sunny WebBox Wireless Connection	11
3.6	Connecting Several Sunny WebBoxes to the Internet	12
3.7	System Configuration with Power Reducer Box for all Compatible Inverter Types	13
3.8	Monitoring Systems for Large-Scale Plants with Sunny WebBox, Power Reducer Box and SMA OPC Server.	14
4	Monitoring Options for Sunny Central (MOW)	15
4.1	Connecting SSM and 1 SCC via Data Line	15
4.2	Monitoring System SC with 1 SC and Sunny WebBox	16
4.3	Monitoring System for Several SC with Sunny WebBox	17
4.4	Monitoring Components in the Communication Combiner.	18
5	Monitoring Options for Sunny Central CP (MOW)	19
5.1	Monitoring System with 1 SC CP	19
5.2	Monitoring System with Several SC CP Units	20
6	Monitoring Options for Sunny Central (US)	22
7	Additional Plant Layout Information	23
7.1	Data Cable Recommendation (Copper)	23

- 7.2 Data Cable Recommendation (Optical Fiber) 24
- 7.3 Members Overview in the RS485 Data Bus or Ethernet Data Bus. . . 24
- 8 Connection Options for Plant Dial-In 25**
- 8.1 Overview 25
- 8.2 Selecting the Best Internet Connection 26
- 9 Contact 27**

1 Introduction

This planning guideline shows the requirements and possibilities of plant monitoring using SMA products. It is intended to serve as orientation for planning a plant monitoring concept.

The planning guideline is intended for planners, engineering offices, purchasers and installers who want to obtain an overview of plant monitoring options using SMA products. It does not substitute the corresponding manuals of the products.

SMA Solar Technology AG will support you when planning your plant monitoring concept. For detailed information on the products, contact the SMA Sales Department.

2 List of the Product-Specific Abbreviations

The following product-specific abbreviations are used in this document:

Abbreviation	Description
OCU	Operational Control Unit
CP	Compact Power
SB	Sunny Boy
SC	Sunny Central
SCC	Sunny Central Control
SMC	Sunny Mini Central
STP	Sunny Tripower
SSM	Sunny String-Monitor
WB	Windy Boy

3 Monitoring Options for Sunny Boy, Sunny Mini Central and Sunny Tripower

3.1 Sunny Beam System with *Bluetooth*® Wireless Technology

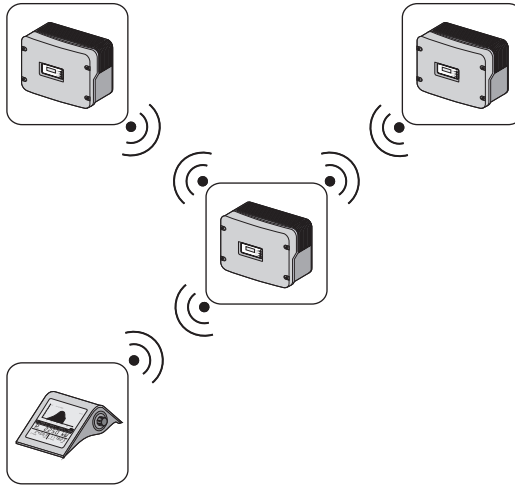

Plant design recommendations

Maximum number of devices	12 inverters
Compatible devices	<p>With integrated <i>Bluetooth</i>:</p> <ul style="list-style-type: none"> • SB 2000HF, SB 2500HF, SB 3000HF • SB 3000TL-20, SB 4000TL-20, SB 5000TL-20 • STP 10000TL, STP 12000TL, STP 15000TL, STP 17000TL <p>Upgraded with <i>Bluetooth</i>:</p> <ul style="list-style-type: none"> • Remaining SB (except for SWR), SMC and WB with SMA <i>Bluetooth Piggy-Back</i>
Maximum distance	<p>With integrated <i>Bluetooth</i>:</p> <ul style="list-style-type: none"> • 100 m in the free field, can be extended by SMA <i>Bluetooth Repeater</i> <p>Upgraded with <i>Bluetooth</i>:</p> <ul style="list-style-type: none"> • 50 m in the free field, can be extended by SMA <i>Bluetooth Repeater</i>
Remote access	None

3.2 Inverter – Computer Direct Connection

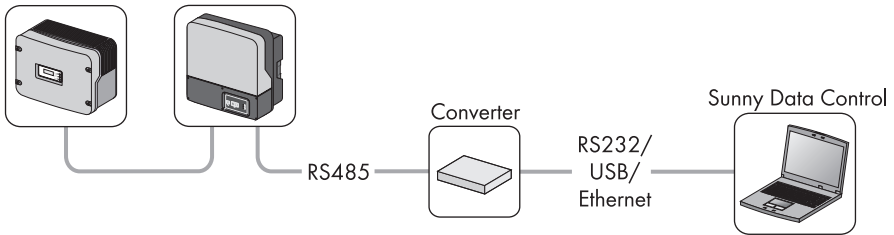

Plant design recommendations

Maximum number of devices	50 inverters
Compatible devices	All SB, SMC, STP, WB with RS485 and Sunny SensorBox
Maximum cable length	1 200 m between first device and the converter
Remote access	Via modem or network connected to the Computer

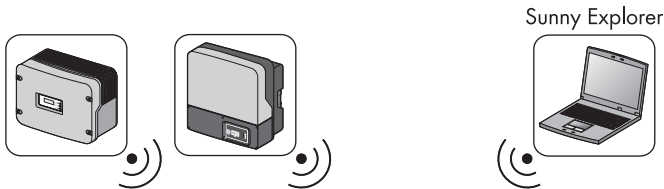

Plant design recommendations

Maximum number of devices	50 inverters
Compatible devices	<p>With integrated <i>Bluetooth</i>:</p> <ul style="list-style-type: none"> • SB 2000HF, SB 2500HF, SB 3000HF • SB 3000TL-20, SB 4000TL-20, SB 5000TL-20 • STP 10000TL, STP 12000TL, STP 15000TL, STP 17000TL <p>Upgraded with <i>Bluetooth</i>:</p> <ul style="list-style-type: none"> • Remaining SB (except for SWR), SMC and WB with SMA <i>Bluetooth Piggy-Back</i>

Maximum distance ^{*)}	With integrated <i>Bluetooth</i> : <ul style="list-style-type: none">• 100 m in the free field, can be extended by SMA <i>Bluetooth Repeater</i> Upgraded with <i>Bluetooth</i> : <ul style="list-style-type: none">• 50 m in the free field, can be extended by SMA <i>Bluetooth Repeater</i>
Remote access	None

^{*)} When using a class 1 *Bluetooth* stick on computer or laptop

3.3 Inverter – Sunny WebBox Connection

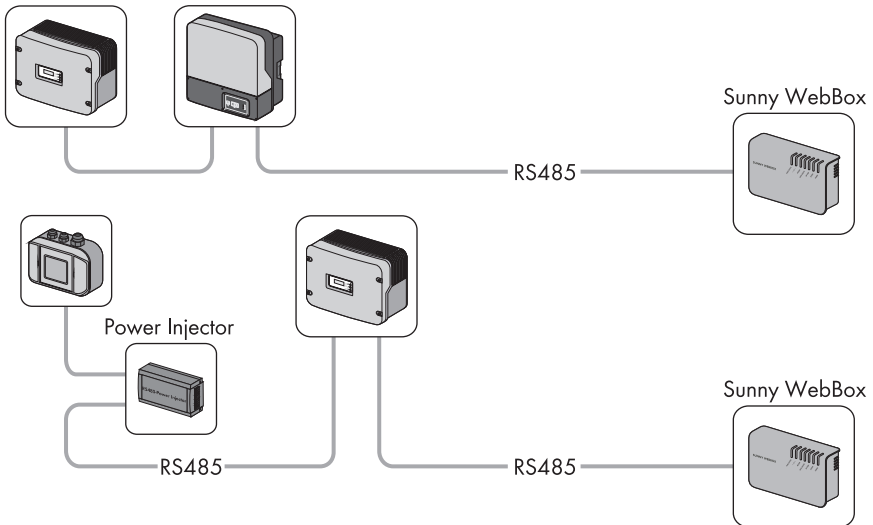

Plant design recommendations

Maximum number of devices	50 devices
Compatible devices	All SB, SMC, STP, WB and Sunny SensorBox
System requirements	<p>With 485QM-10-NR:</p> <ul style="list-style-type: none"> • SB 2000HF, 2500HF, 3000HF <p>With DM-485CB-10:</p> <ul style="list-style-type: none"> • SB 3000TL-20, SB 4000TL-20, SB 5000TL-20 • STP 10000TL, STP 12000TL, STP 15000TL, STP 17000TL <p>With RS485 Piggy-Back:</p> <ul style="list-style-type: none"> • Remaining SB, SMC and WB
Maximum cable length	<ul style="list-style-type: none"> • 1 200 m between first device and Sunny WebBox • 150 m between Sunny SensorBox and Power Injector
Remote access	Optional internal analogue or GSM modem and external connection to network or DSL-access

3.4 Inverter – Sunny WebBox Bluetooth Connection

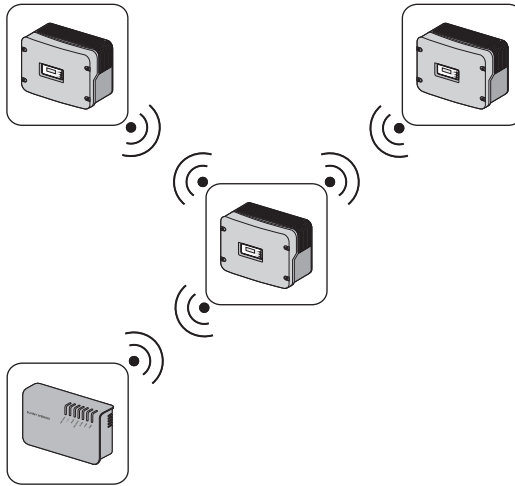

Plant design recommendations

Maximum number of devices	50 inverters with 1 master 25 inverters with 2 masters
Compatible devices	<p>With integrated <i>Bluetooth</i>:</p> <ul style="list-style-type: none"> • SB 2000HF, SB 2500HF, SB 3000HF • SB 3000TL-20, SB 4000TL-20, SB 5000TL-20 • STP 10000TL, STP 12000TL, STP 15000TL, STP 17000TL <p>Upgraded with <i>Bluetooth</i>:</p> <ul style="list-style-type: none"> • Remaining SB (except for SWR), SMC and WB with SMA <i>Bluetooth Piggy-Back</i>
Maximum distance	<p>With integrated <i>Bluetooth</i>:</p> <ul style="list-style-type: none"> • 100 m in the free field, can be extended by SMA <i>Bluetooth Repeater</i> <p>Upgraded with <i>Bluetooth</i>:</p> <ul style="list-style-type: none"> • 50 m in the free field, can be extended by SMA <i>Bluetooth Repeater</i>
Remote access	External connection to network or DSL/GSM - access via Ethernet interface

3.5 Inverter – Sunny WebBox Wireless Connection ^{*)}

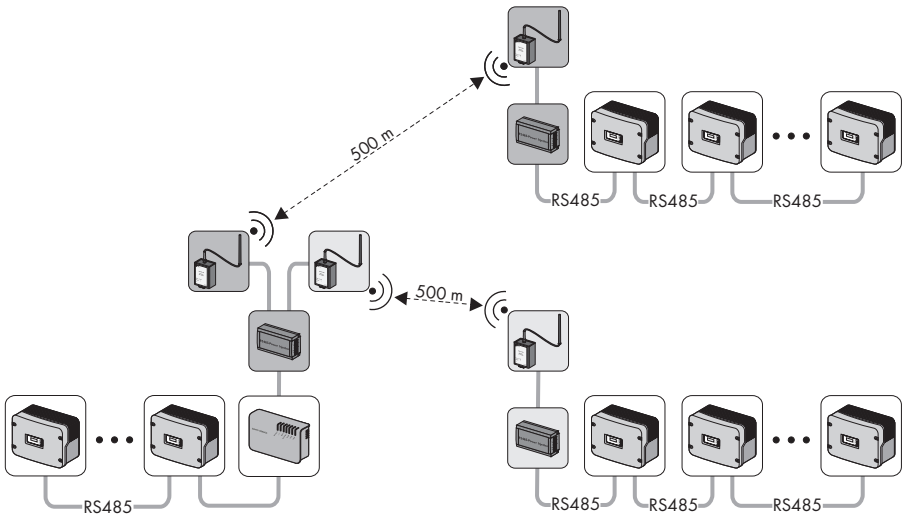

Plant design recommendations

Maximum number of devices	50 inverters
Compatible devices	All SB, SMC, STP, WB and Sunny SensorBox
System requirements	<p>With 485QM-10-NR:</p> <ul style="list-style-type: none"> • SB 2000HF, SB 2500HF, SB 3000HF <p>With DM-485CB-10:</p> <ul style="list-style-type: none"> • SB 3000TL-20, SB 4000TL-20, SB 5000TL-20 • STP 10000TL, STP 12000TL, STP 15000TL, STP 17000TL <p>With RS485 Piggy-Back:</p> <ul style="list-style-type: none"> • Remaining SB, SMC and WB with RS485 Piggy-Back
Maximum cable length	1 200 m for the RS485 data line Additionally 500 m in the free field between wireless converters
Remote access	Optional internal analogue or GSM modem and external connection to network or DSL-access

^{*)} Using example with wireless set 485-01 and wireless set 485-02.

3.6 Connecting Several Sunny WebBoxes to the Internet

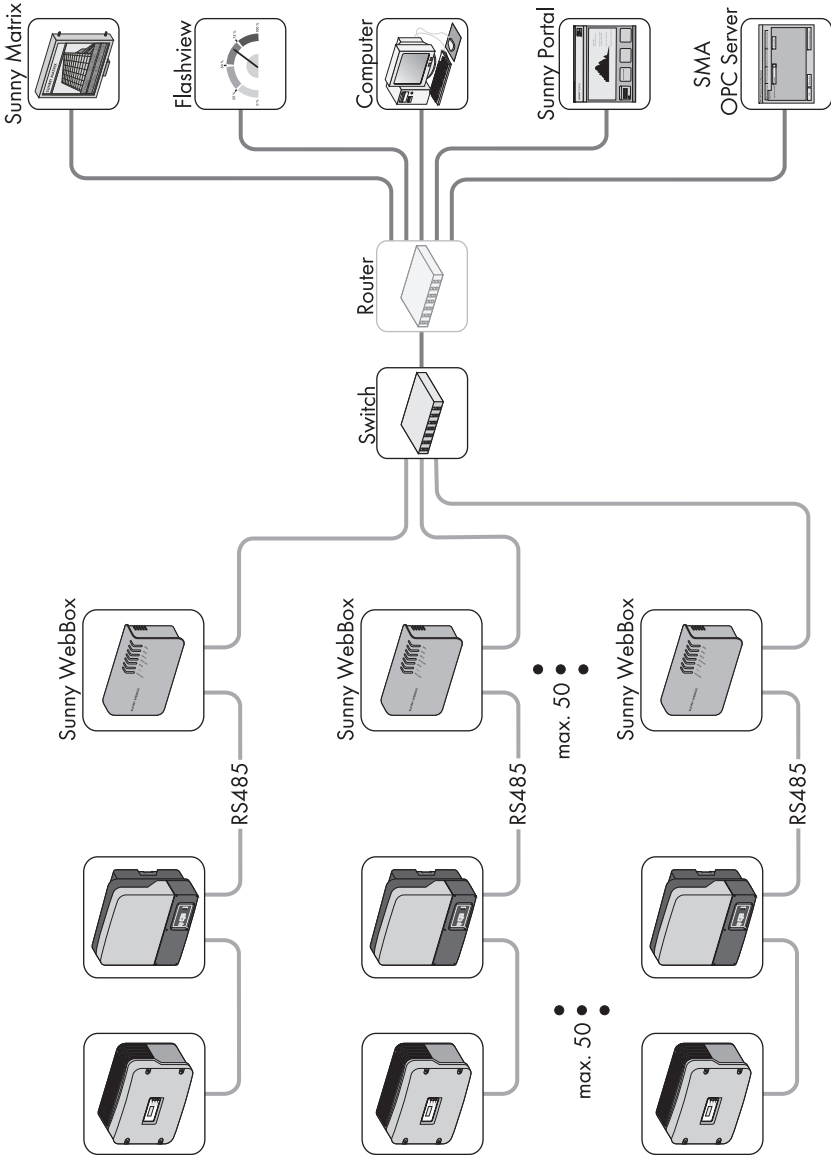

3.8 Monitoring Systems for Large-Scale Plants with Sunny WebBox, Power Reducer Box and SMA OPC Server

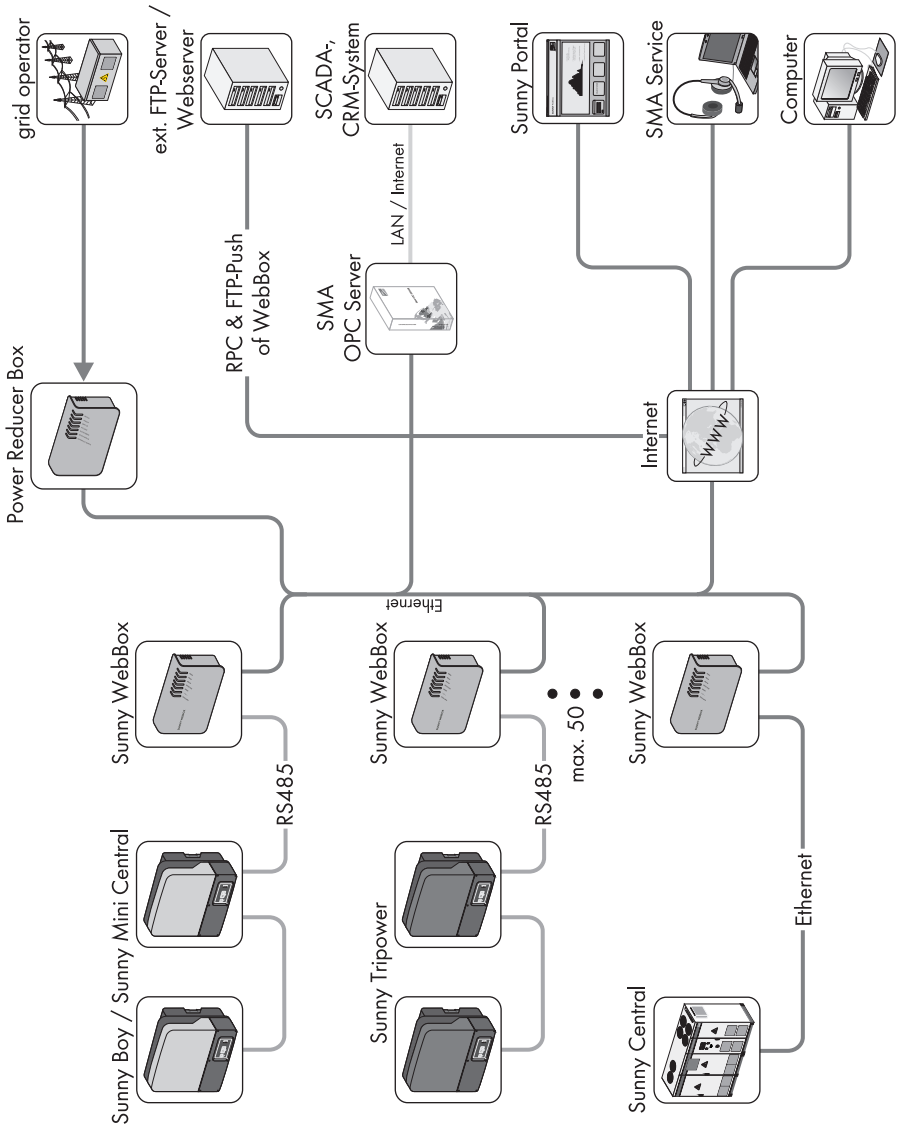

4 Monitoring Options for Sunny Central (MOW)

4.1 Connecting SSM and 1 SCC via Data Line

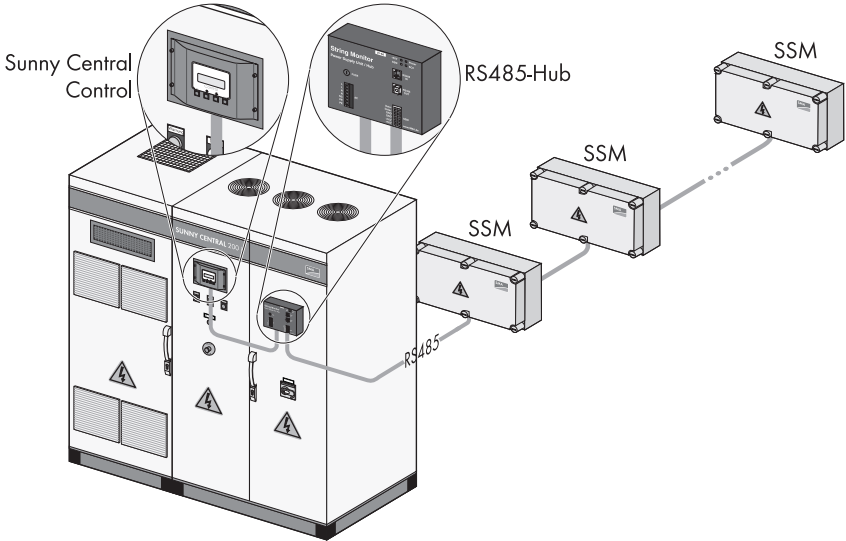

Plant design recommendations

Maximum number of devices	10 SSM, 5 SSM16 or 3 SSM24 per RS485 hub The maximum number of SSM per SC depends on the inverter type and power.
Maximum cable length	1 200 m for the RS485 data line
Remote access	External router connected via Ethernet to the SCC

4.2 Monitoring System SC with 1 SC and Sunny WebBox

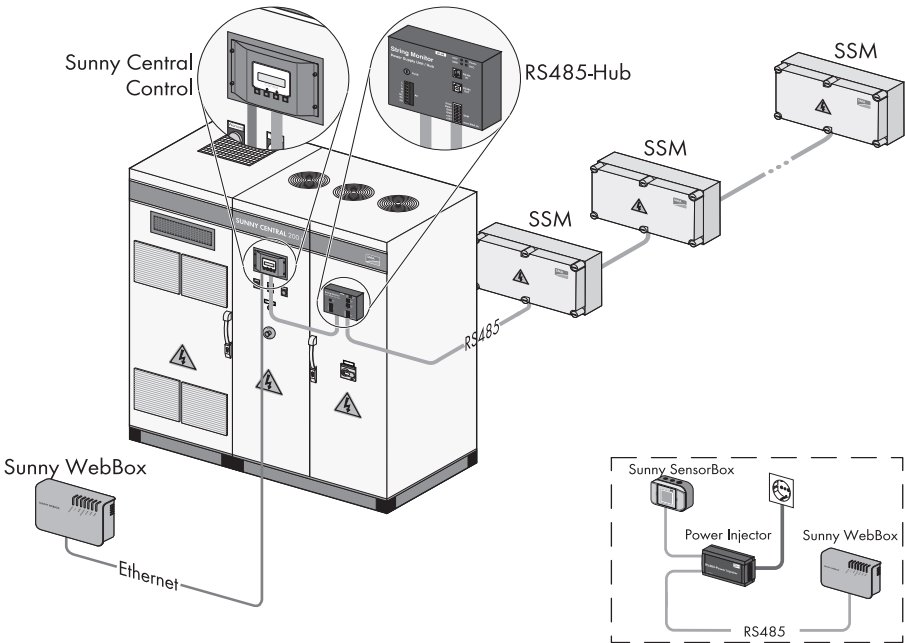

Plant design recommendations

Maximum number of devices	<ul style="list-style-type: none"> • 10 SSM, 5 SSM16 or 3 SSM24 per RS485 hub <p>The maximum number of SSM per SC depends on the inverter type and power.</p> <ul style="list-style-type: none"> • 50 devices per Sunny WebBox ^{*)}
Maximum cable length	<ul style="list-style-type: none"> • 1 200 m for the RS485 data line • 100 m for Ethernet connection
Remote access	External Router connected via Ethernet to the Sunny WebBox

^{*)} See section 7.3 "Members Overview in the RS485 Data Bus or Ethernet Data Bus" (page 24).

4.3 Monitoring System for Several SC with Sunny WebBox

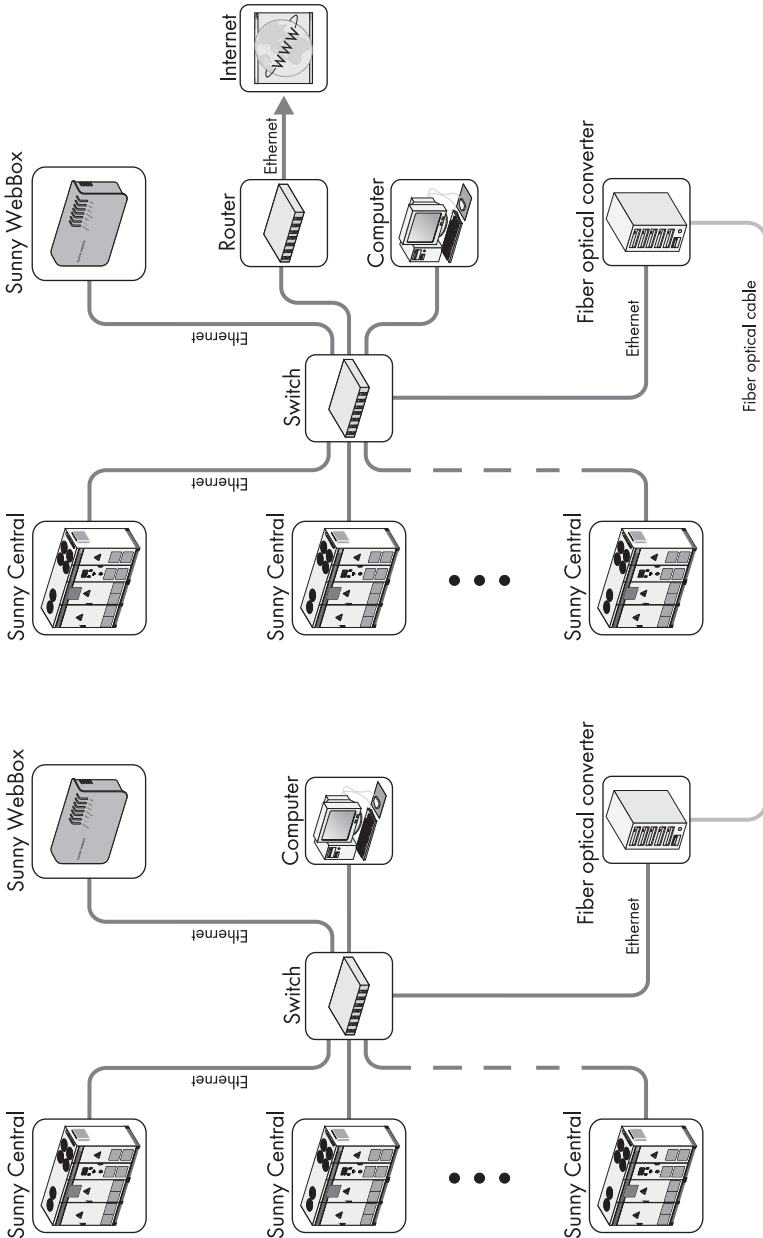

4.4 Monitoring Components in the Communication Combiner ^{*)}

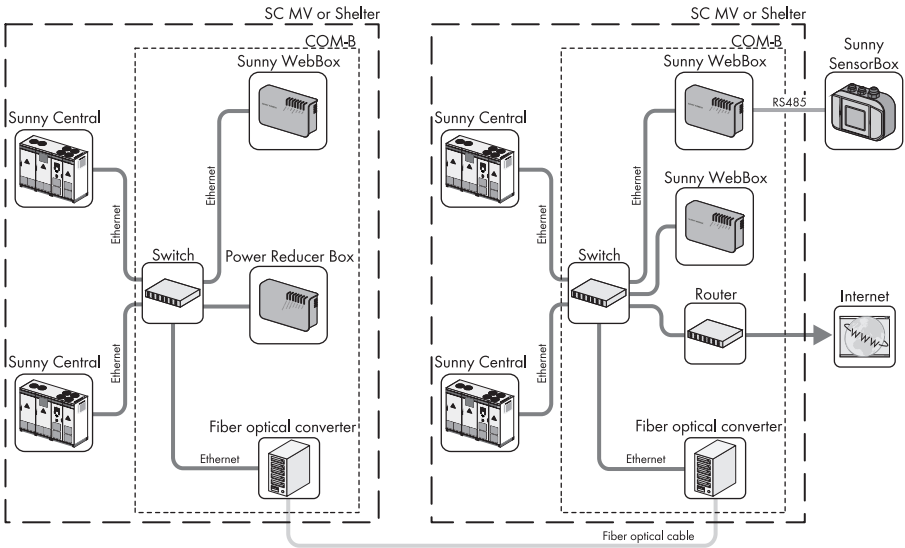

Plant design recommendations

<p>Maximum number of devices</p>	<ul style="list-style-type: none"> • 50 devices per Sunny WebBox^{**)} The devices include: <ul style="list-style-type: none"> - SCC - OCU - SSM - Sunny SensorBox • 8 Ethernet devices at 8 port switch • Separate Sunny WebBoxes for data acquisition via RS485 (e.g. for Sunny SensorBox) and via Ethernet.
<p>Maximum cable length</p>	<ul style="list-style-type: none"> • 1 200 m for the RS485 data line • 100 m for Ethernet connection • 2 000 m with multi-mode optical fiber • 15 000 m with multi-mode optical fiber
<p>Remote access</p>	<ul style="list-style-type: none"> • External router connected to switch; available as GSM/GPRS/UMTS or DSL

^{*)} Using the example with COM-B systems with a larger number of communication devices can also be implemented with COM-C.

^{**)} 1 Sunny Central corresponds to 1 x SCC + 1 x OCU = 2 devices, see section 7.3 "Members Overview in the RS485 Data Bus or Ethernet Data Bus" (page 24).

5 Monitoring Options for Sunny Central CP (MOW)

5.1 Monitoring System with 1 SC CP

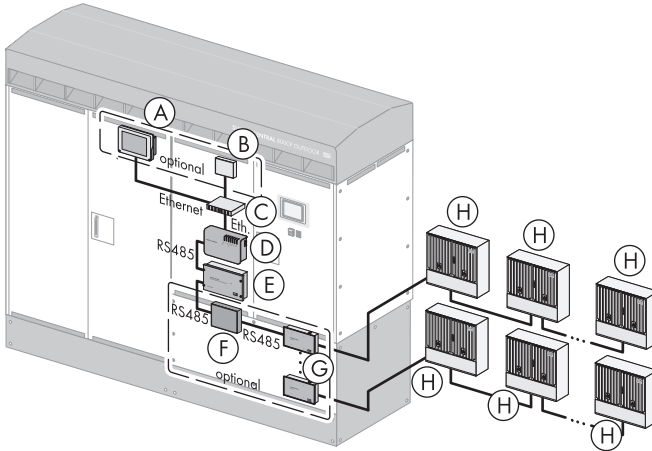

Plant design recommendations

Devices	
Position	Description
A	Sunny Display for SC
B	Optical fiber ^{*)} converter
C	Ethernet switch
D	Sunny WebBox
E	SC Controller
F	SSM Controller
G	RS485 hub for SSM
H	SSM
Maximum number of devices	10 SSM, 5 SSM16 or 3 SSM24 per RS485 hub The maximum number of SSM per SC depends on the inverter type and power.
Maximum cable length	<ul style="list-style-type: none"> • 1 200 m for the RS485 data line • 100 m for Ethernet connection • 2 000 m with multi-mode optical fiber • 15 000 m with multi-mode optical fiber
Remote access	External Router connected via Ethernet to the Sunny WebBox

^{*)} Fiber optical cable with 1 optical fiber interface

5.2 Monitoring System with Several SC CP Units

Wiring recommendation 1

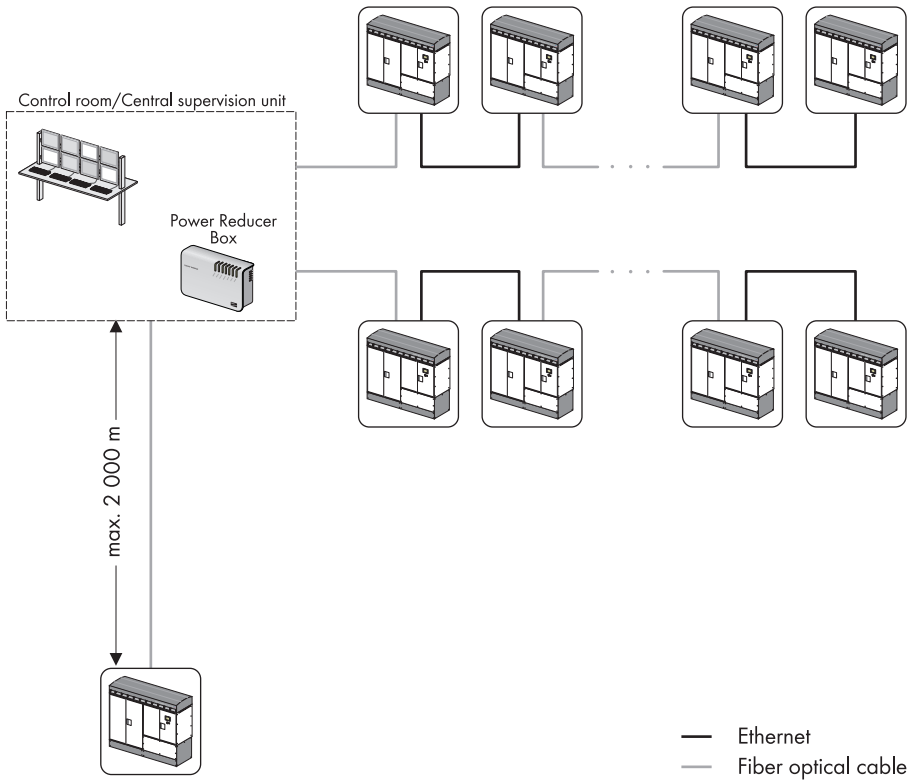

Wiring recommendation 2

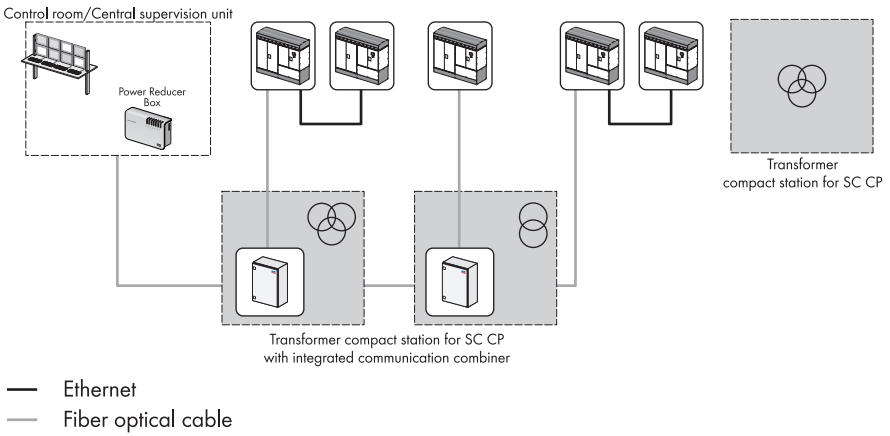

6 Monitoring Options for Sunny Central (US)

Monitoring System with 1 SC US

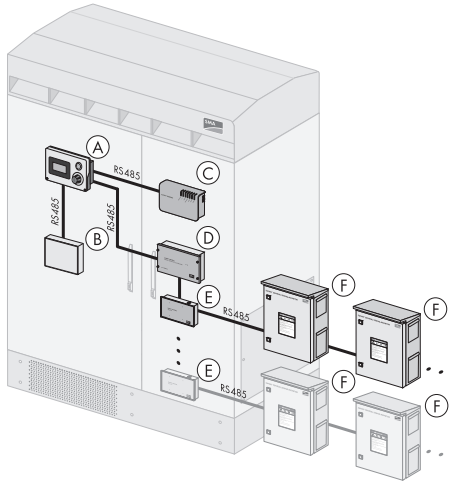

Plant design recommendations

Devices	
Position	Description
A	Sunny Display for SC
B	SC Controller Mainboard
C	Sunny WebBox
D	SC String-Monitor Controller
E	RS485 hub for SSM
F	Sunny Central String-Monitor
Maximum number of devices	<ul style="list-style-type: none"> • 50 devices per Sunny WebBox • 9 SSM-US on SC 500U, SC 500HE-US • 6 SSM-US on SC 250U
Maximum cable length	<ul style="list-style-type: none"> • 1 200 m for the RS485 data line • 100 m for Ethernet connection
Remote access	<ul style="list-style-type: none"> • External router connected to switch; available as GSM/GPRS/UMTS or DSL

7 Additional Plant Layout Information

7.1 Data Cable Recommendation (Copper)

Applies to all monitoring options.

Communication cable

RS485 for SB, SMC and STP	Twisted pair of wires LiYCY 2 x 2 x 0.25 mm ²
RS485 for SSM	Twisted pair of wires Li-2YCYv 4 x 2 x 0.5 mm ²
Cable for Power Reducer Box	LiYY 5 x 0.5 mm ²

Ethernet cable

Type	Manufacturer's designation	Properties
CAT 5 indoor	Lapp ETHERLINE® H CAT.5e	2 x 2 x AWG24/1
CAT 6 indoor	Lapp ETHERLINE® Y PiMF CAT.6a	4 x 2 x AWG26/19
CAT 7 indoor	Lapp ETHERLINE® Y PiMF CAT.7	4 x 2 x AWG22/1
CAT 5 outdoor	Lapp ETHERLINE® Y2Y ARM Type A CAT.5	2 x 2 x AWG22/1

Device

Type	Manufacturer's designation
Switch 5 port	Industrial Ethernet switch 10/100Mbps-5 x RJ45
Switch 8 port	Industrial Ethernet switch 10/100Mbps-8 x RJ45
Media converter Multi-mode optical fiber (SC)	Industrial Ethernet converter RJ45/Multi-mode optical fiber (SC), ICP-GmbH IMC-101-M-SC-T
Media converter Single-mode optical fiber (SC)	Industrial Ethernet converter RJ45/Single-mode optical fiber (SC), ICP-GmbH IMC-101-S-SC-T
Sunny WebBox	-
Power Reducer Box	-

7.2 Data Cable Recommendation (Optical Fiber)

Cable

Type	Manufacturer's designation	Properties
Multi-mode optical fiber cable, buried cable	Lapp HITRONIC® HQN1000 8G 50/125 (1000N)	8G50/125
Single-mode optical fiber cable, buried cable	Lapp HITRONIC® HQN1000 8E 9/125 (1000N)	8E9/125

Device

Type	Manufacturer's designation
Media converter	Industrial Ethernet converter
Multi-mode optical fiber (SC)	RJ45/Multi-mode optical fiber (SC), ICP-GmbH IMC-101-M-SC-T
Media converter	Industrial Ethernet converter
Single-mode optical fiber (SC)	RJ45/Single-mode optical fiber (SC), ICP-GmbH IMC-101-S-SC-T

7.3 Members Overview in the RS485 Data Bus or Ethernet Data Bus

Type	Number of devices
Sunny SensorBox	Corresponds to 1
RS485-Power Injector	-
Sunny Boy	Corresponds to 1
Sunny Mini Central	Corresponds to 1
Sunny Tripower	Corresponds to 1
Sunny String-Monitor SSM	Corresponds to 1
Sunny String-Monitor SSM 16-11	Corresponds to 2
Sunny String-Monitor SSM 24-11	Corresponds to 3
Sunny Central Controller	Corresponds to 1
Sunny String-Monitor Controller	Corresponds to 1
Sunny Central HE-11	Corresponds to 2
Sunny Central CP	Corresponds to 2

8 Connection Options for Plant Dial-In

8.1 Overview

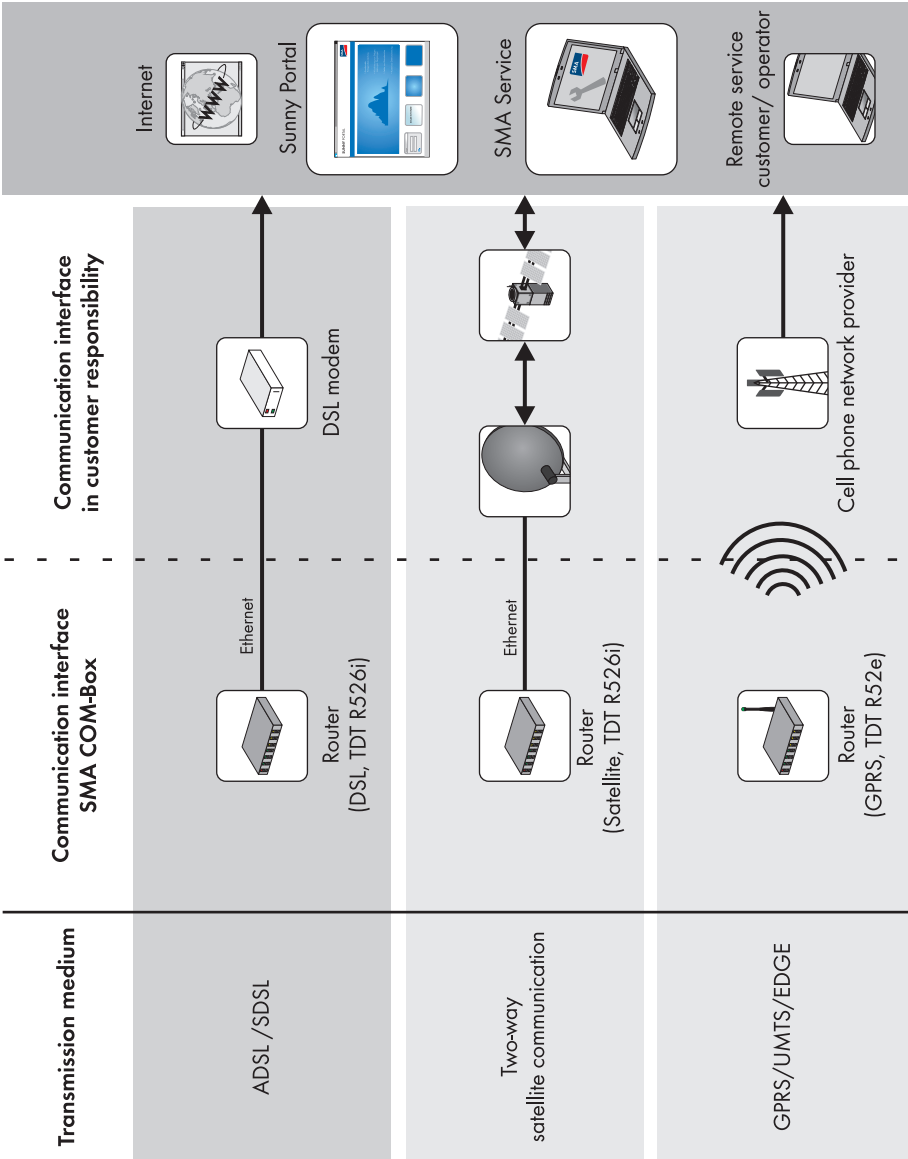

8.2 Selecting the Best Internet Connection



The number of devices specified in the figure below ensures a sufficient data transmission to the Sunny Portal. Depending on the location, tariff and technology used, you can also connect several devices to one terminal.

Connection types and router	Number of devices	
DSL*) Router: R526i	SC of CP series	98
	Remaining SC	178
	SB / SMC / STP	615
DSLtoSAT**) Router: R526i	SC of CP series	24
	Remaining SC	44
	SB / SMC / STP	153
UMTS***) Router: R52u	SC of CP series	14
	Remaining SC	26
	SB / SMC / STP	92
EDGE Router: R52u	SC of CP series	6
	Remaining SC	11
	SB / SMC / STP	38
GPRS Router: R52	SC of CP series	6
	Remaining SC	11
	SB / SMC / STP	38

*) DSL modem is not included in scope of delivery.

***) Satellite system is not included in scope of delivery.

****) Without HSUPA (High Speed Uplink Packet Access).

9 Contact

For detailed information on the products, contact the SMA Sales Department.

SMA Solar Technology AG

Sonnenallee 1

34266 Niestetal

Telefon: +49 561 9522 4000

E-Mail: ad-guide@SMA.de

The information contained in this document is the property of SMA Solar Technology AG. Publishing its content, either partially or in full, requires the written permission of SMA Solar Technology AG. Any internal company copying of the document for the purposes of evaluating the product or its correct implementation is allowed and does not require permission.

Exclusion of liability

The general terms and conditions of delivery of SMA Solar Technology AG shall apply.

The content of these documents is continually checked and amended, where necessary. However, discrepancies cannot be excluded. No guarantee is made for the completeness of these documents. The latest version is available online at www.SMA.de or from the usual sales channels.

Guarantee or liability claims for damages of any kind are excluded if they are caused by one or more of the following:

- Damages during transportation
- Improper or inappropriate use of the product
- Operating the product in an unintended environment
- Operating the product whilst ignoring relevant, statutory safety regulations in the deployment location
- Ignoring safety warnings and instructions contained in all documents relevant to the product
- Operating the product under incorrect safety or protection conditions
- Altering the product or supplied software without authority
- The product malfunctions due to operating attached or neighboring devices beyond statutory limit values
- In case of unforeseen calamity or force majeure

The use of supplied software produced by SMA Solar Technology AG is subject to the following conditions:

- SMA Solar Technology AG rejects any liability for direct or indirect damages arising from the use of software developed by SMA Solar Technology AG. This also applies to the provision or non-provision of support activities.
- Supplied software not developed by SMA Solar Technology AG is subject to the respective licensing and liability agreements of the manufacturer.

SMA Factory Warranty

The current guarantee conditions come enclosed with your device. These are also available online at www.SMA.de and can be downloaded or are available on paper from the usual sales channels if required.

Trademarks

All trademarks are recognized even if these are not marked separately. Missing designations do not mean that a product or brand is not a registered trademark.

The *Bluetooth®* word mark and logos are registered trademarks owned by Bluetooth SIG, Inc. and any use of such marks by SMA Solar Technology AG is under license.

SMA Solar Technology AG

Sonnenallee 1

34266 Niestetal

Germany

Tel. +49 561 9522-0

Fax +49 561 9522-100

www.SMA.de

E-Mail: info@SMA.de

© 2004 to 2010 SMA Solar Technology AG. All rights reserved

SMA Solar Technology

www.SMA-Solar.com

SMA Solar Technology AG

www.SMA.de

SMA America, LLC

www.SMA-America.com

SMA Technology Australia Pty., Ltd.

www.SMA-Australia.com.au

SMA Benelux SPRL

www.SMA-Benelux.com

SMA Beijing Commercial Co., Ltd.

www.SMA-China.com

SMA Czech Republic s.r.o.

www.SMA-Czech.com

SMA France S.A.S.

www.SMA-France.com

SMA Hellas AE

www.SMA-Hellas.com

SMA Ibérica Tecnología Solar, S.L.

www.SMA-Iberica.com

SMA Italia S.r.l.

www.SMA-Italia.com

SMA Technology Korea Co., Ltd.

www.SMA-Korea.com

